

BARRICADES & BARRICADE LIGHTS

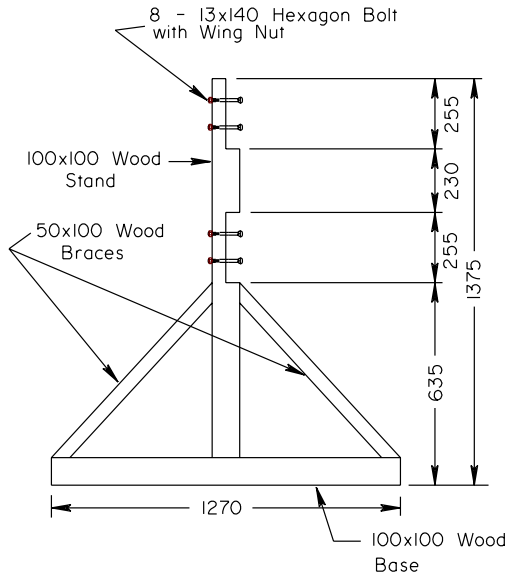

www.foxcanada.net | sales@foxcanada.net | 1-866-548-8147

Barricades

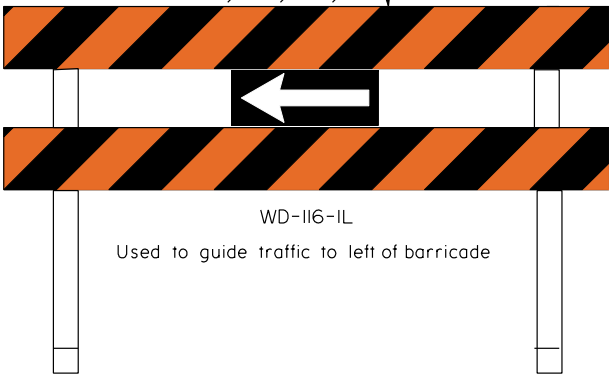
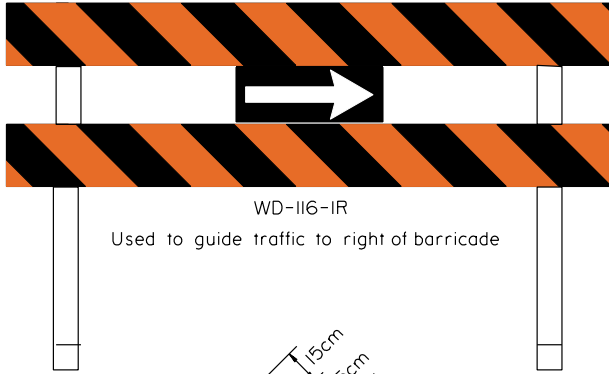

WD-116-3

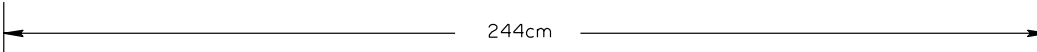

WD-116-2

Bridge Out and Road Closed boards may be used to replace one diagonal stripe board where appropriate. All dimensions are in millimetres unless otherwise indicated.

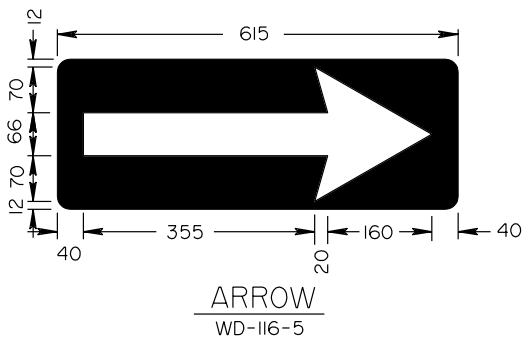

△			
△			
No.	REVISIONS	BY	DATE
Approved:			
Executive Director, Technical Standards Branch			
Date:	MARCH, 2001		
STANDARD BARRICADE USED FOR CONSTRUCTION PROJECTS			
Prepared By: G.E.C.	Checked By: P.H.	Scale: N.T.S.	Dwg No.: TCS-B-4.2 MISCELLANEOUS

FILE TCSB4m2.SGN



Solar LED Barricade Lights

- Solar Powered - No batteries Required
- Impact-Resistant yellow housing with UV stabilizers
- Available in Red or Amber 7" Lens
- Super Bright LED, 14000 +mcd light output
- 100,000 hours of LED life expectancy
- Available in 3.25 or 3.75 Version
- Can Operate up to 5 nights on a single charge
- Recharges even during cloudy weather
- Environmentally Friendly
- Solar Panel is rated at 0.4w

Available models:

- DL-MAVERICK-A (Amber)
- DL-MAVERICK-R (Red)